

Set-up instruction guitar.

The microphone can be attached on the outside of the top as well as on the inside. To find the right position on the inside it is easiest to first find the best position on the outside.

This instruction is about attaching on the outside but is partly applicable when attaching on the inside.

It is advisably to let a professional attaching it on the inside. An end pin with a 6,3mm contact will then be attached. And perhaps also a volume control.

The microphone is delivered with blue-tack, cable ties and adapter. The blue-tack does not harm the instrument and works well during time. Is recommended for attaching on the outside. If you still are concerned about fat spots from the blue-tack it is easy to detach the microphone and the blue-tack when not playing.

For attaching on the inside use mounting pads or silicone instead of blue-tack.

Notice! The wood has to be even and completely dust free so the pads/silicon really stick to the top. The wood can be prepared, after cleaned, with a *thin* layer of diluted warmish on the spot where the pads should be attached. Apply with a cloth.

Instruction attaching on the outside

Cut the blue-tack in to four equal parts and stick them easily to the corners on the lower surface of the microphone. The quantity in each corner should be equivalent to a ball with a diameter of approx. 5 mm.

Note! The blue-tack is to be stuck to the lower surface. Not to the top surface. A "STY" is seen on the top side.

"STY" should be seen and the label text turned right when the microphone is attached.

Press the microphone on the top of the guitar. Turn it gently back and forth until the gap between the microphone and the top is a little less than 1mm. 0,7 – 0,9 mm is usually good. 8 layers of ordinary copy paper gives about 0,8 mm. The distance is, however, not too delicate.

Normally blue-tack does not discolour the top. But I can't give any guarantees depending on how the top is varnished and with what. If you are worried I recommend you to remove the microphone and the blue-tack when the instrument is not in use. Detaching and attaching is very easy when you once have found the optimal place so this is no bigger inconvenience.

Here you can see how it looks like on the bottom of the microphone after attachment. Using silicone/mounting pads these should be as large.

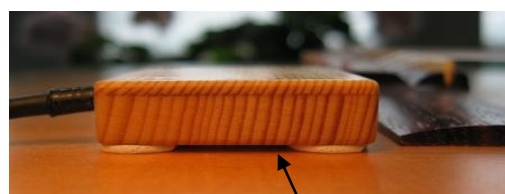

It is delicate regarding the sound where the microphone is attached on the top. It is also individually for each single instrument. This must be tested out. Take your time. The blue-tack makes it very easy to change position. Note, even turning the microphone may give some change. Attach the microphone at first in the area shown on the image. Here it is most likely to find a good position. Then test by moving around the microphone in small moves. Attaching as shown on the image will be good for a start.

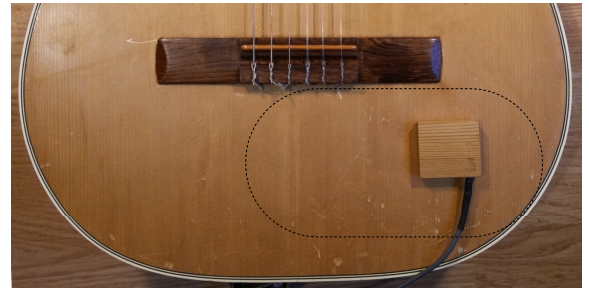

For weight reason a small 3,5 mm contact is mounted. It is essential the cable strain on the microphone is kept to a minimum. Consequently a relatively thin cable and a light contact. But a 3,5 contact is not fixed so hard as a 6,3 one. Therefore the best solution is to use the enclosed adapter 3,5 mm - 6,3 mm and attach it to the shoulder strap with the cable ties as shown in the images.

Using the adapter in this way keeps the cable strain on the microphone to a minimum. At the same time there is a steady connection (6,3 mm). You just need to make four small holes in the lower leather part of the shoulder strap. Tighten up the cable ties hard and the adapter will be steady. In this way it will also be very easy to attach and detach the microphone if you want to use it on another instrument.

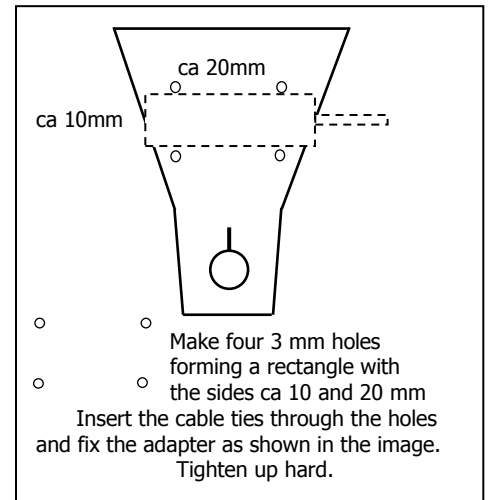

Those not using a shoulder strap may take a piece of leather with the same shape and size. Make a hole in it to fit the end pin and attach the adapter as above. It is then easy to move the piece of leather with adapter between various instruments.

More ways to attach the contact/adapter se bellow.

It is most important the cable does not pull the microphone.

If the microphone is attached inside the instrument all this is of no interest. The cable will instead be connected to a 6,3 mm contact replacing the end pin. This is, however, a job for a professional.



As a standard the cable is approx. 30 cm long for the guitar and 55 cm for the double base . Shorter or longer is no problem.

More ways to attach the contact/adapter:

Attach the contact/adapter with the help of one or two cable ties and a thin rope. Then tie the rope around the end pin.



Attach the contact or the adapter with two cable ties as shown. One of the cable ties is tightened around the end pin.

